

The background of the entire page is a photograph of a person climbing a large, dark rock face. The person is silhouetted against a bright, low sun, creating a lens flare effect. The sky is a mix of orange and blue, and the overall scene is dramatic and inspiring.

vimec

V6r
TECHNICAL CATALOGUE

March 2026

OVERVIEW

V6 Straight rails	
Rail size (mm)	80*40
Max, guide rails length	10 mt.
Slope (min-max)	0° - 45°
Min. encumbrance of rail (mm)	125
Min footprint when platform is closed (mm)	420
Capacity (up to 40°)	300 kg
Capacity (over 40°)	225 kg
Speed	0,10 m/s
Battery power supply	24 Vdc
Power consumption	0,2 kW
Usage environment	Indoor/outdoor
Operating temperature	-5°C/ +50°C
Compliant with the European Directive 2014/30 "Electromagnetic compatibility"	
Compliant with Machinery Directive 42/2006	



OVERVIEW

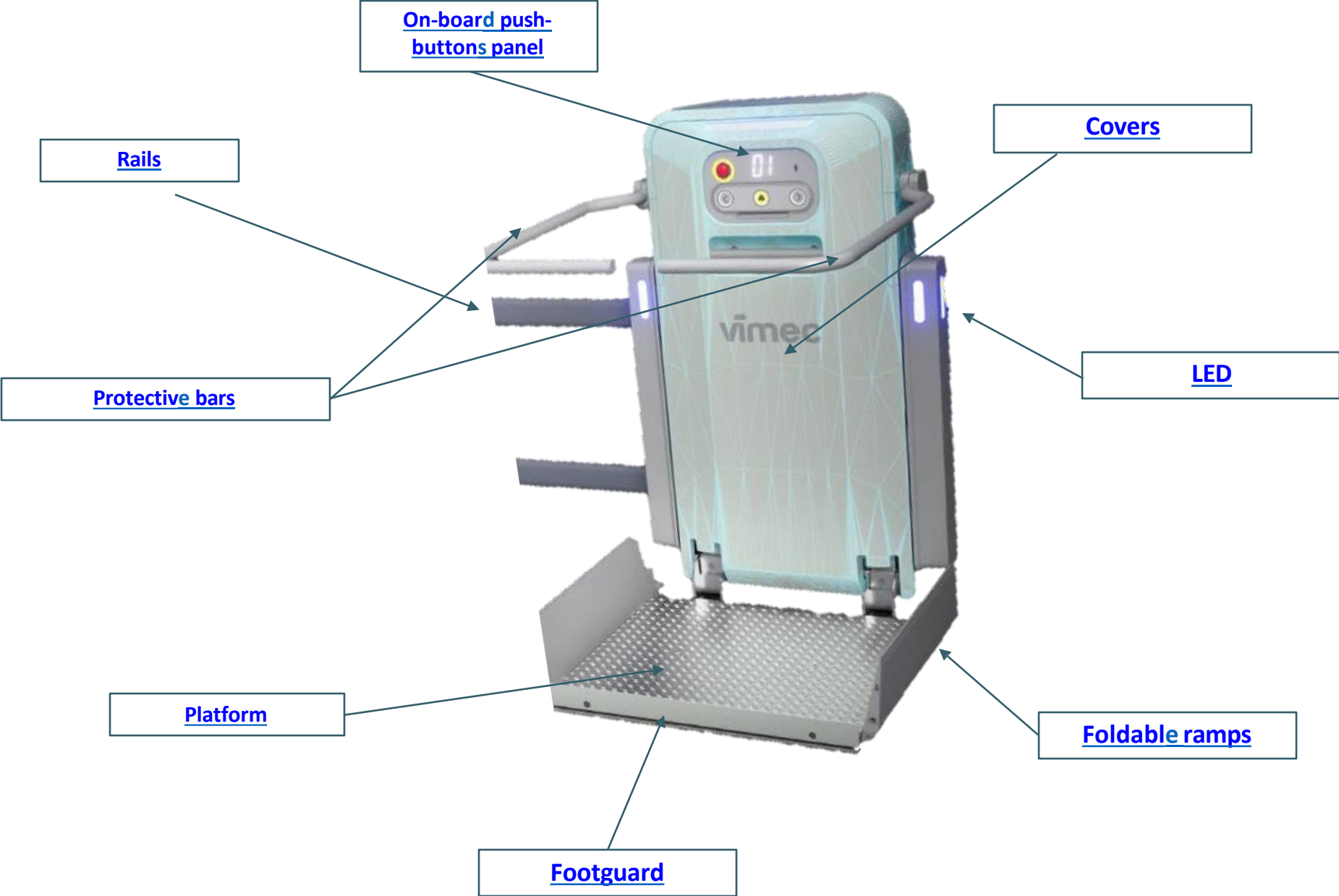

EN 81-40 - CHECKLIST



Below, we list all the points of the EN 81-40 standard respected by V6s:

Requirements	EN 81-40 ref.
Flame retardant and self-extinguishing materials	5.1.4.
Overload sensor (<i>std for 1250x800, 1000x900, 1000x800</i>)	5.1.6.2
IP 44 protection of the electrical system	5.1.8.2
Double chain traction with safety sensor	5.4.1.5
Driving pinion safety factor	5.4.5.1
Anti-trapping and anti-crushing guards	5.4.8.5
Two-way communication device (standard)	5.5.16.1
LED lights visual signs (standard)	5.5.16.2
Anti-slip walkable surface	5.6.4.1
Footguard 75 mm (upon request)	5.6.4.4.3
Handrail	5.6.4.5.2
Gaps between bars = 100 mm	5.6.4.5.3

DIMENSIONS — OVERVIEW

V6										
L	<i>Platform width</i>	750	750	750	800	900	900	1000	1000	1250
P	<i>Platform depth</i>	600	650	700	700	700	800	800	900	800
	Rail encumbrance w/ wall fittings (mm)	95								
	Rail encumbrance w/ std fittings (mm)	125								
	Rail encumbrance w/ self-supporting fittings (mm)	195								
D	Min. closed platform (also with seat)	420								
		445	430							
D*	Min. closed platform with footguard EN81-40 (also with seat)	450								
		490	450							
D**	Min. closed platform with front access	545	555	565			585		610	585
	Capacity up to 40°	300 kg								
	Capacity over 40°	225 kg								
		N.A.								

NEW SIZE

NEW DESIGN

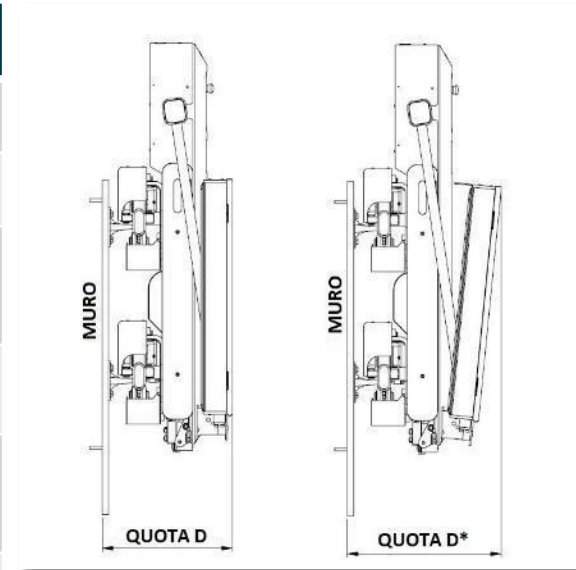

- with self-supporting supports +70mm
- with wall fixing -30mm

DIMENSIONS – MACHINE BODY

V6

NEW SIZE

L	Platform width	750	750	750	800	900	900	1000	1000	1250
P	Platform depth	600	650	700	700	700	800	800	900	800
I	Min. lateral encumbrance	920	970	1020			1120		1220	1120
T	Platform width with open flaps	1120			1170	1270		1370		1620
T1	Width with extended bars	805				905		1005		1255
H1* (including the height of the platform base from floor = 30mm)	Height with open bars	1810	1860	1910			2010			
R	Bar path Radius	685	735	785				885		
W	Width with front access	1055	1105	1155			1255	1355	1255	

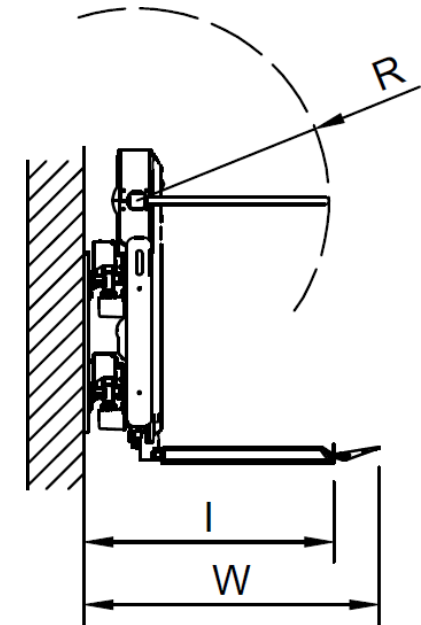
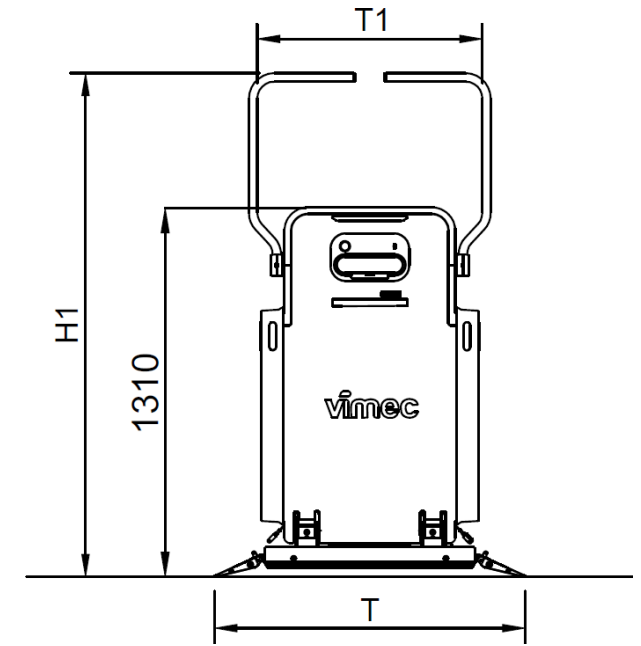

DIMENSIONS – FRONT VIEW

V6										
L	Platform width	750	750	750	800	900	900	1000	1000	1250
P	Platform depth	600	650	700	700	700	800	800	900	800
A*	Lateral Access		2350	2400	2500	2600	2850			
B*	Landing rail footprint		1150	1200	1300	1400	1650			
N*	Machine footprint on starting landing		1350	1400	1500	1600	1850			
C*	Bars in working position		1820	1850	1910	1970	2110			

NEW SIZE

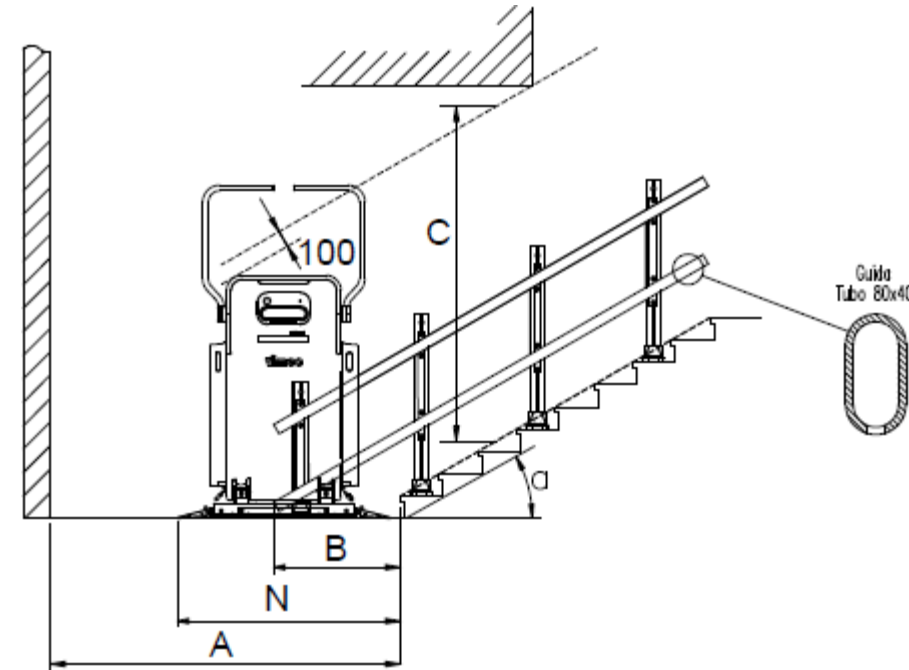

*platform sizes non available with 225mm duty load

DIMENSIONS – VIEW FROM ABOVE

V6										
L	Platform width	750	750	750	800	900	900	1000	1000	1250
P	Platform depth	600	650	700	700	700	800	800	900	800
	With std. fixings and lateral access	920	970	1020			1120		1220	1120
	With std. Fixings, lateral access and front access	1055	1105	1155			1255		1355	1255

NEW SIZE

NEW DESIGN

- with self-supporting supports +70mm.
- with wall fixing -30mm

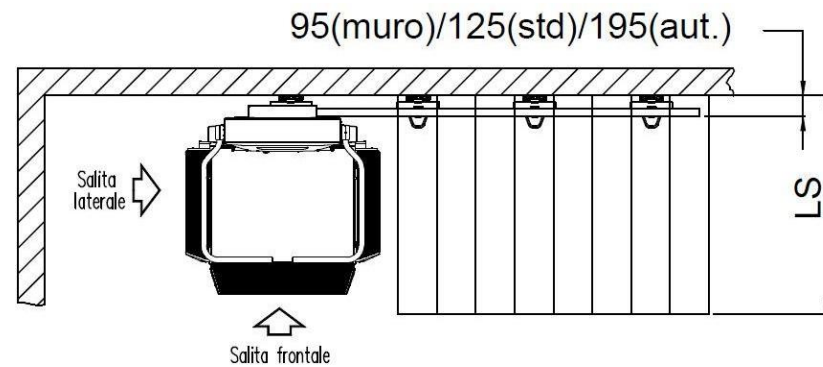

DIMENSIONS – CLOSED PLATFORM HEIGHT FRONT ACCESS

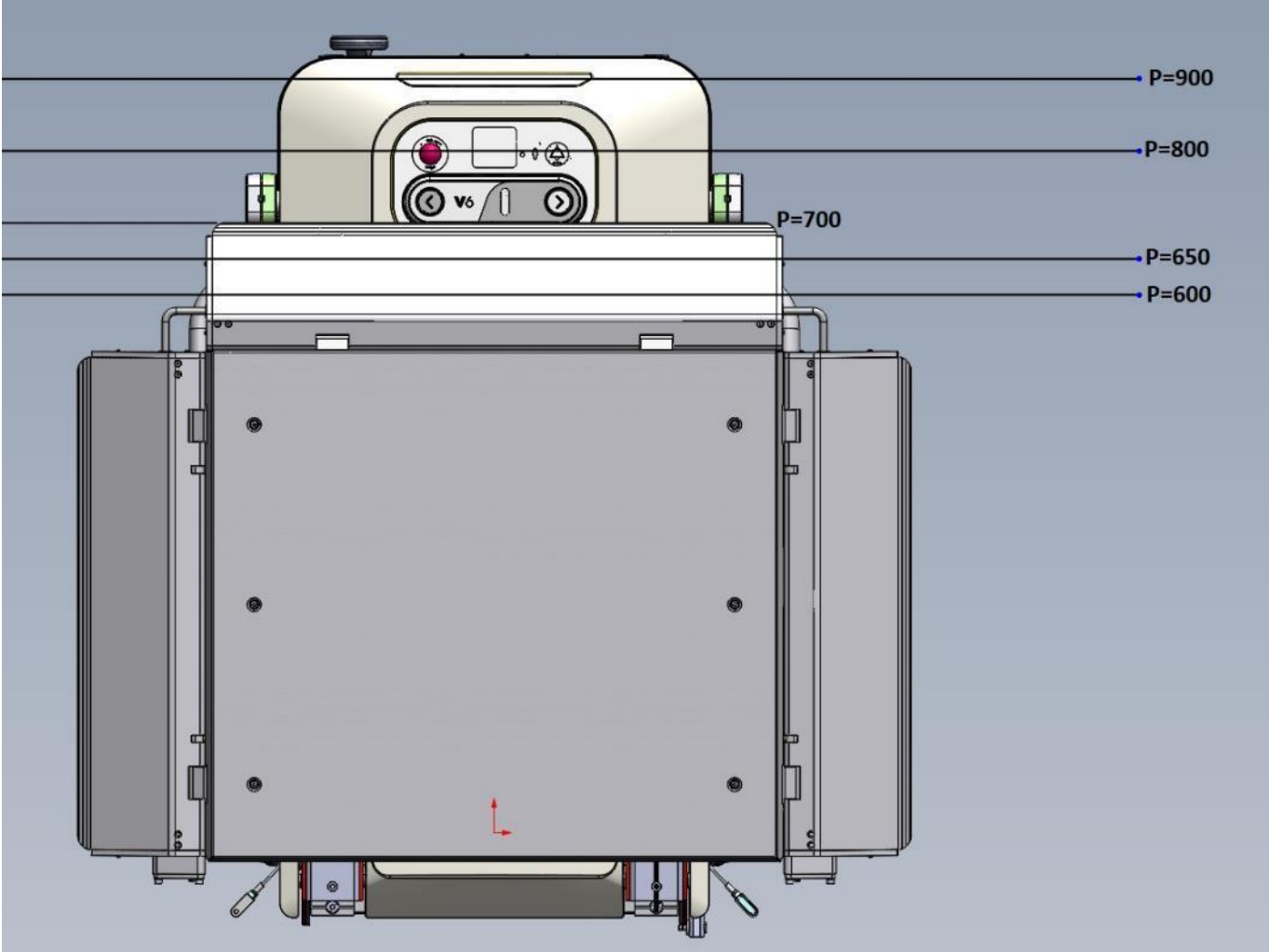

DIMENSIONS – CLOSED PLATFORM HEIGHT FRONT ACCESS

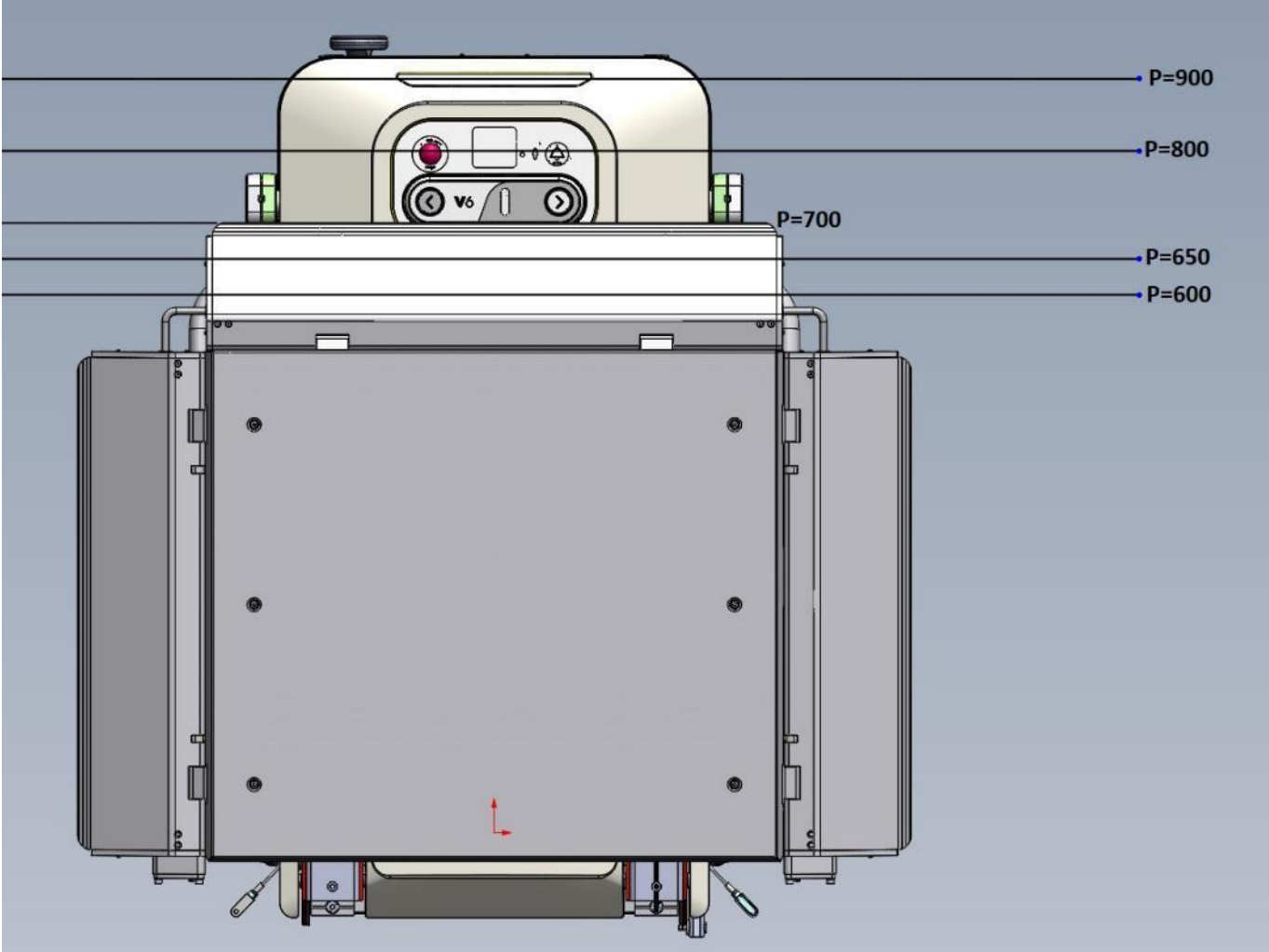

DIMENSIONS – CLOSED PLATFORM HEIGHT LATERAL ACCESS

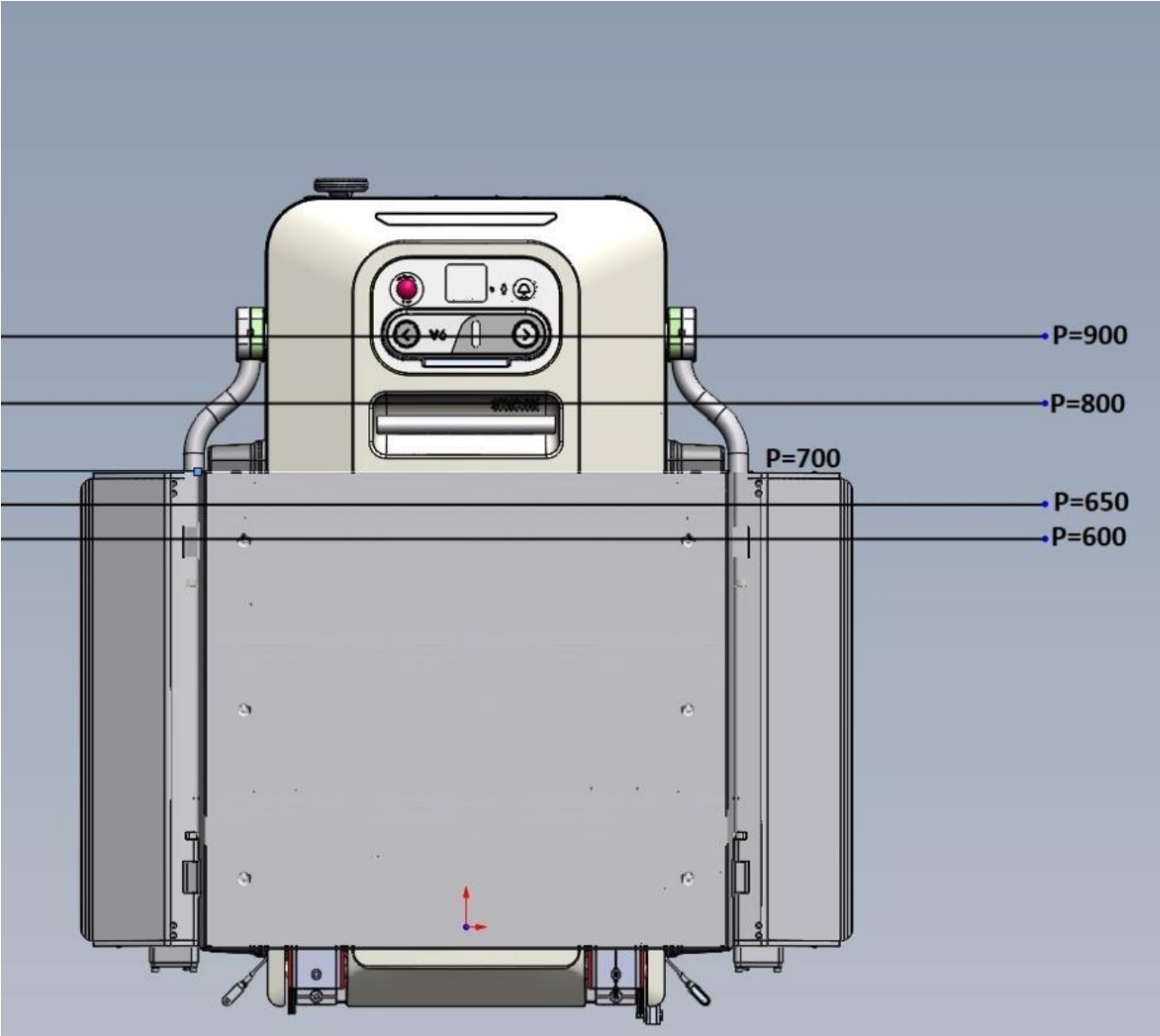

SALES MEMO – ON-BOARD CONTROLS

Recessed red stop button to prevent accidental activation



Backlit display as standard -



In RAL 7047 Telegrey 4 for all versions



Directional buttons with extended active part – the whole area can be easily activated even without the use of hands!



ON-BOARD PUSH-BUTTON PANEL

ON BOARD

The standard on-board push-button panel is made of thermoplastic material and is 170 x 280 mm in size.

The on-board control panel includes:

- Round directional buttons with arrow for ascent and descent
- Emergency "bell" button
- Stop button
- [Display and indicator lights](#)
- Magnetic activation key

The **arrow** and **bell buttons** are rounded and have a diameter of 40 mm – the entire surface is active to allow you to press the button more easily even without the use of your hands. Only the directional keys have the backlit crown.

The operation of the two directional buttons is of “dead’s man” type and it is therefore necessary to constantly hold the button until the platform reaches the floors and stops automatically.

The **bell button** is always active regardless of the status of the key and it activates an **audible alarm** and the **auto-dialer** when present.



DISPLAY AND INDICATOR LIGHTS

Overload light

White LED

- [Overload sensor](#) standard for 1250x800 , 1000x900 and 1000x800
Optional for other platforms

Fault reporting

White LED

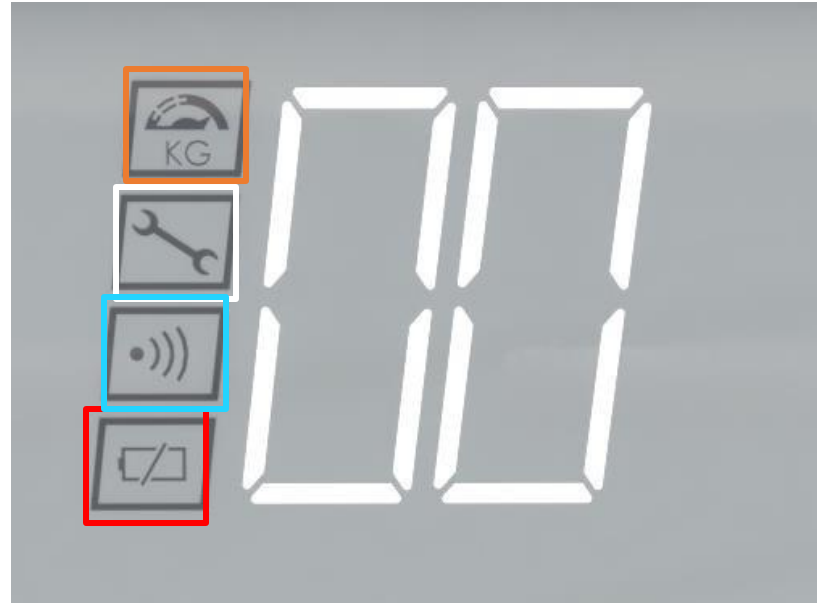

Radio signal reception

White LED

It is activated when the floor remote control or the remote control for attendant is used.

Battery signal

Green LED: battery charged

Orange LED: battery not fully charged

Red blinking LED: charging battery

V6 is equipped as standard with an **LED light display** located behind the dashboard cover. The symbols appear via backlight and then, when the machine is not running and not in error, the display is not visible.

The display provides information on the status and activity of the machine, in particular:

- **DIRECTION OF TRAVEL:** the display shows directional arrows in motion
- **FLOOR** where the car is located
- **ERROR CODES:** When the machine is in error, the display shows the corresponding error code to facilitate the technician and/or users in resolving the problem. Some errors are recoverable and can be fixed directly by the user through the user manual or the [app MyVimec](#).

LED

V6 is equipped to standard with **1 RGBW LED strip**, positioned above the control panel and 2 optional ones placed on each side bumper.

The LEDs provide in an intuitive and immediate way some information on the status and activity of the machine, in detail:

- **GREEN LED fixed**
Machine ready to be used
- **BLUE LED flashing**
Moving machine
- **RED LED flashing**
Movement not possible (e.g. due to obstruction)
- **RED LED fixed**
Machine in error
- **GREEN LED flashing**
Machine in self-centering zone
- **YELLOW LED flashing**
Machine called from the floor



OTHER FEATURES

All the V6 are integrated with a **handrail** made of **plastic** and colored RAL 9006. The handrail placed in the upper part of the stairlift is used as a support during the motion.

The "recessed" position of the handle avoids any accidental impact. The length is 268 mm, and the diameter is 25 mm.

Compliant with regulation [EN 81-40, 5.6.4.5.2](#), the space around the handle must be greater than 30 mm to ensure a comfortable grip for users.

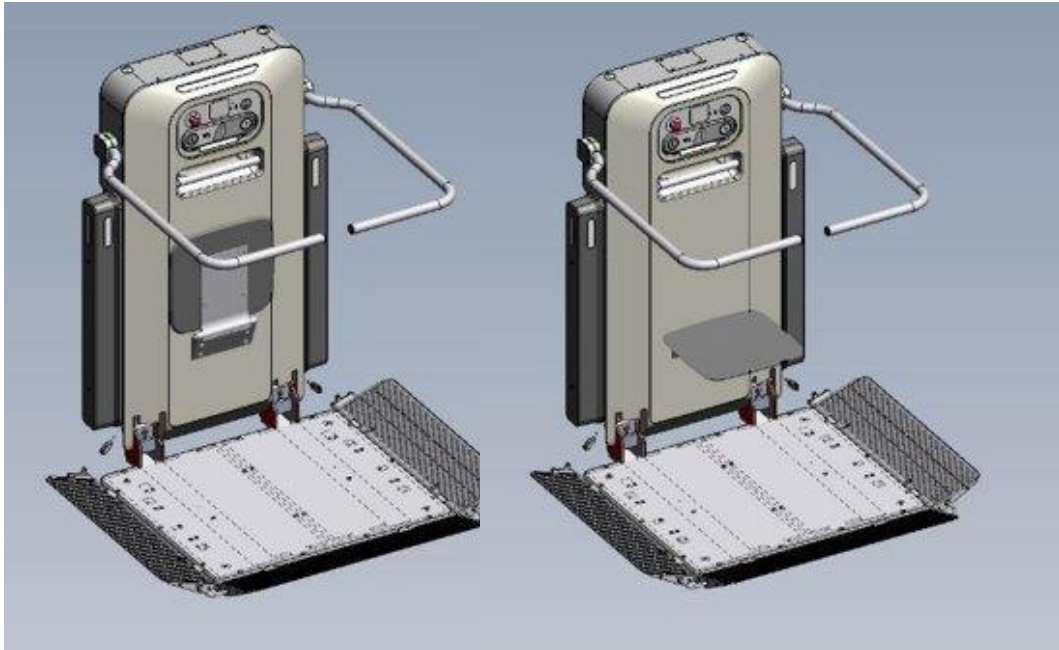

A **folding seat** with a maximum capacity of **130 kg** can also be ordered as an option.

The presence of the seat does not affect the footprint of the closed machine.

COVERS

V6 has been designed to adapt to every condition and environment of use.

In particular, all hoods, caps and side panels have an **IP 44** rating which means that "internal" electrical and electronic devices are protected against the penetration of solid foreign bodies with a diameter of 1 mm and above and is protected from splashing water from all directions.

In addition, these components are fireproof or self-extinguishing and classified as **V0** according to the UL94 standard "Degree of Extinguishing of Plastics" – this means that in the event of a fire, the flame is extinguished within 10 seconds.

 **COMPLIANT** Compliant with regulation [EN 81-40, 5.1.4](#)



Front cover available in
RAL 9018 or 7024



Rear covers



SALES MEMO – PROTECTIVE BARS

ALUMINIUM
RAL 9006



SIMPLE MANUAL UNLOCKING



DISTANCE BETWEEN BARS IN
ACCORDANCE WITH 81-40
Between 100 and 150 mm



 COMPLIANT



FOLDABLE
DOWNWARDS



INTERLOCKED BARS



 COMPLIANT

FLOOR CONTROLS

In the standard equipment of V6s, **a radio push-button panel is provided for each served floor.** The push-button panel consists of a wall housing and a removable remote control.

Using the **O** "call" button, the machine is called back to the desired floor.
Using the **P** "parking" button, the machine is sent to parking.

All push-button panels are enabled by a **removable magnetic key** - you cannot use the machine without the key being inserted.

2 keys are provided for each standard supplied push-button panel (4 keys in total).
The remote control is supplied with a 3.7V rechargeable battery.

As with the on-board controls, all the floor controls are "dead's man" type (just remove your finger from the button and the machine stops).

As option, it is possible to request for a radio-push button panel for the attendand (with a maximum of 3 pieces each machine).



ACCESS – PLATFORM

V6s is always equipped with a **motorised platform** through an electromechanical actuator - it is necessary to keep the C button pressed on the push-button panel for the platform to open automatically, the connecting flap will be placed in the boarding position and the descent side bar in the working position.



A special manual manoeuvre allows you to close the platform in emergency conditions (see dedicated [slide](#)).

The platform is also protected by **safety flaps** on the right and left sides, with lateral access, and on 3 sides with front access (optional), which have the dual function of facilitating the ascent to the floors (open position) and containing the wheelchair during the path of the machine. Before the machine leaves the plane, the flaps are automatically brought to the safety position (inclined at 75°).

The flap facing the descent opens only on the lower floor of the path. In case of resistance to the movement of the flaps, an overcurrent protection intervenes by blocking the recalled function.

In case of standard side access, the platform is always equipped with a **front foot guard** with a standard height of 5.5 cm.

As an option, the foot guard is available
EN 81-40 with height 7.5 cm.

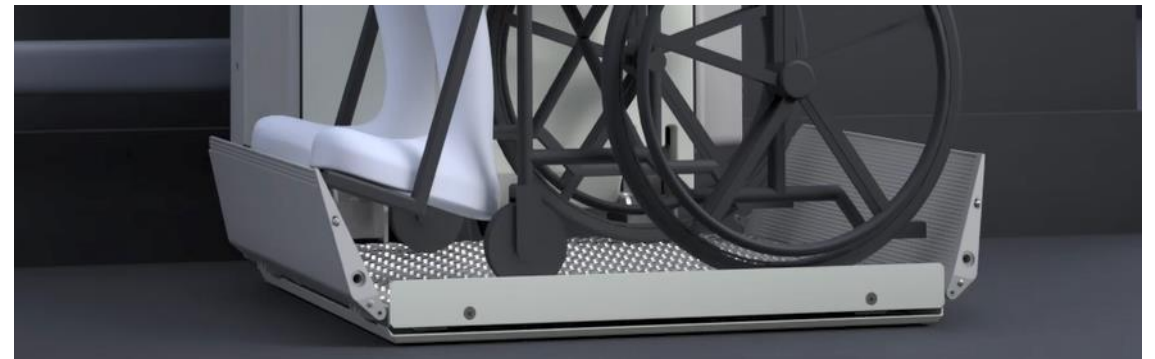

ACCESS – PLATFORM



All the platforms are also equipped with **SAFETY EDGES UNDER THE PLATFORM** – under the platform are in fact installed microswitches able to stop the platform in the event that, moving down, there is any obstacle between the staircase / floor and the platform. Until the obstacle is removed, the platform cannot proceed in its downward movement but can instead climb to allow the removal of the obstacle or the landing on the upper floor.

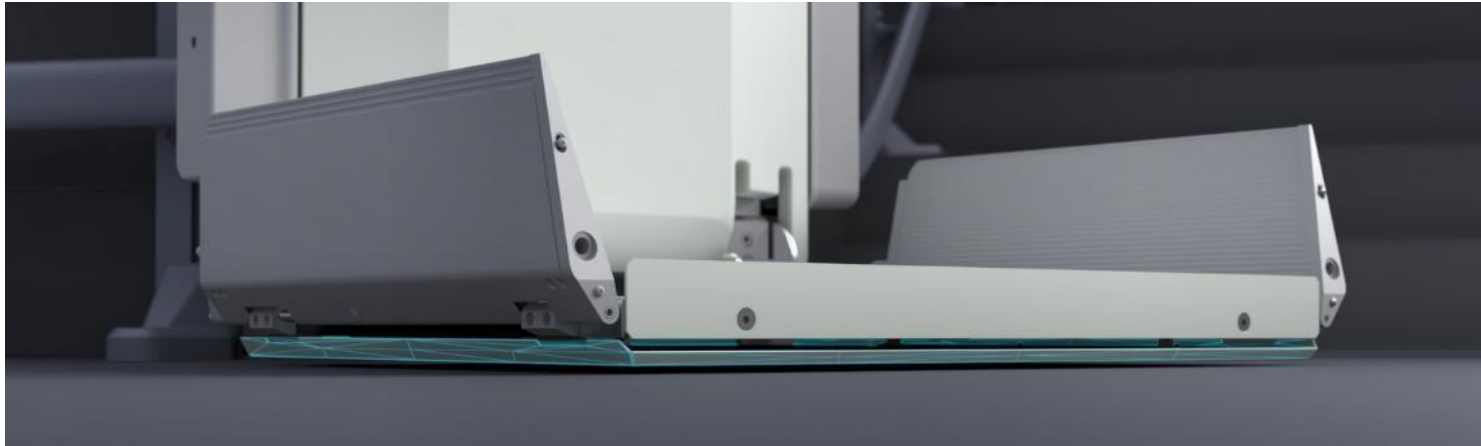

All platforms can be equipped with an **overload sensor** that aims to check for any overloads of the platform. In case of overload, the inclinometer causes the appropriate indicator light on the display to light and stops the machine.

The overload sensor is standard on 1250x800, 1000x900 and 1000x800 platform sizes.

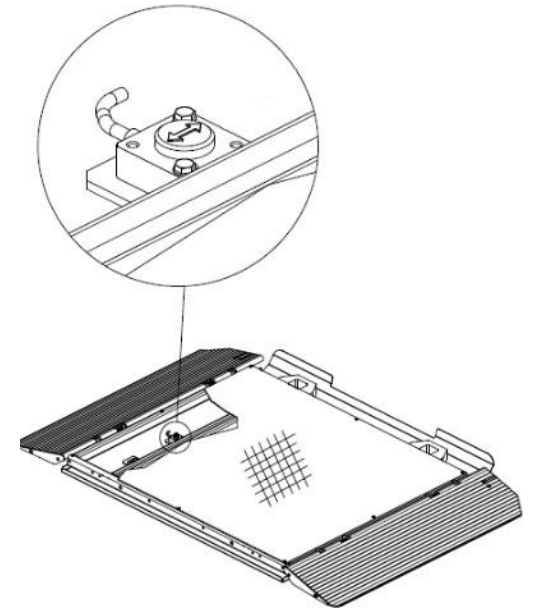

MYVIMEC APP – TECHNICIAN

The MyVimec app is a very useful tool available to the technician / maintainer because, through bluetooth connection with the machine, it will allow you to:

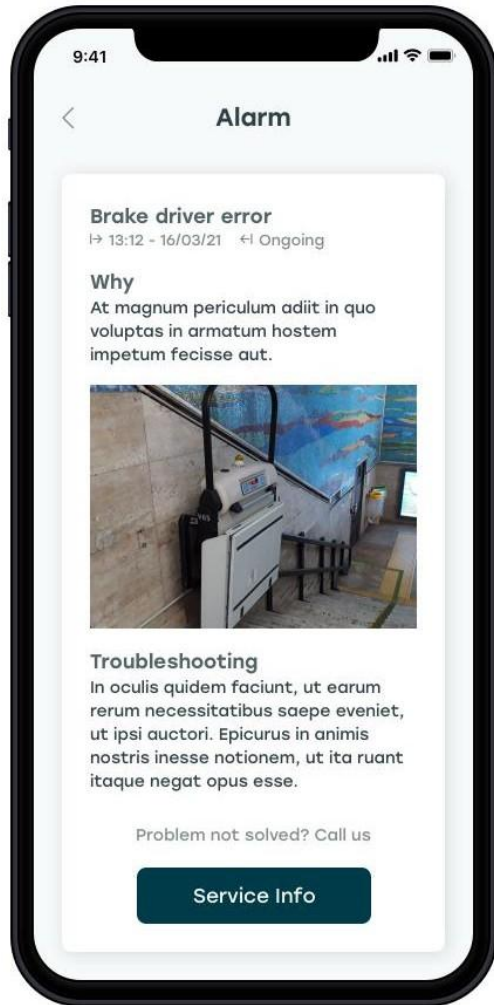

- Receive real-time information on the **status** of the machine (e.g. battery charge level, machine position, etc.)
- Receive real-time information about machine **alarms** or **error** codes and machine recovery instructions
- **Configure** the machine on site
- Carry out **tests** (functionality still being defined)

CONNECTIVITY

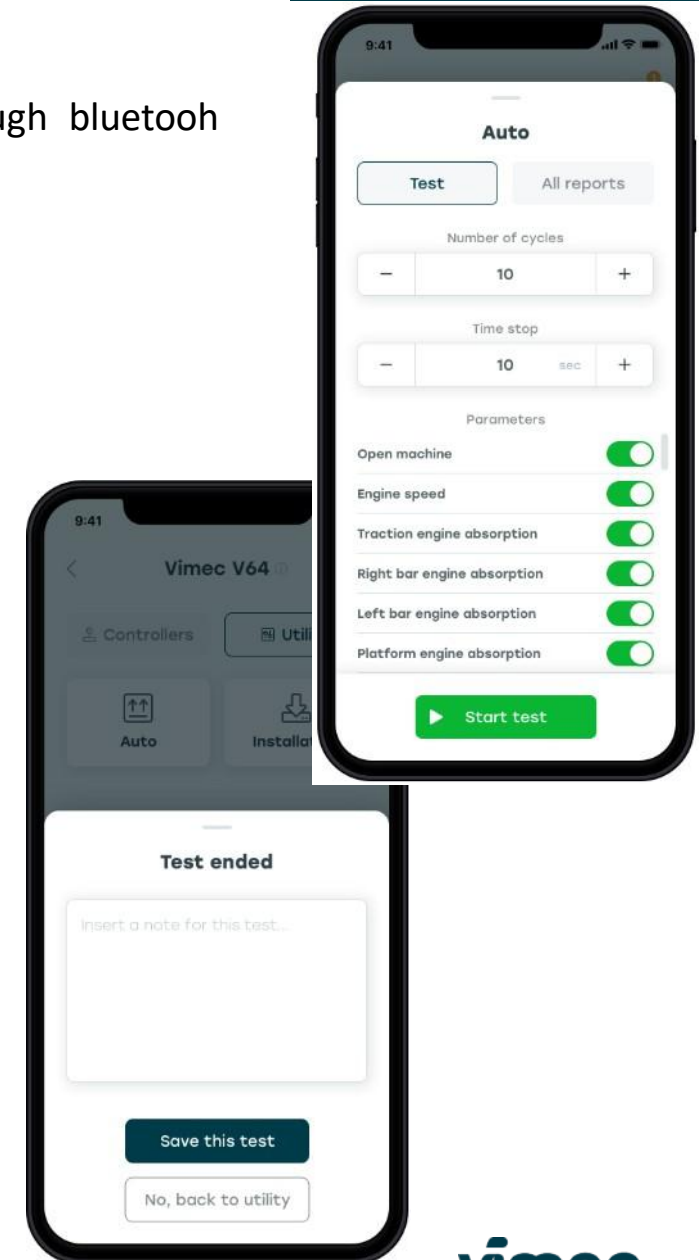

SALES MEMO – TRACTION

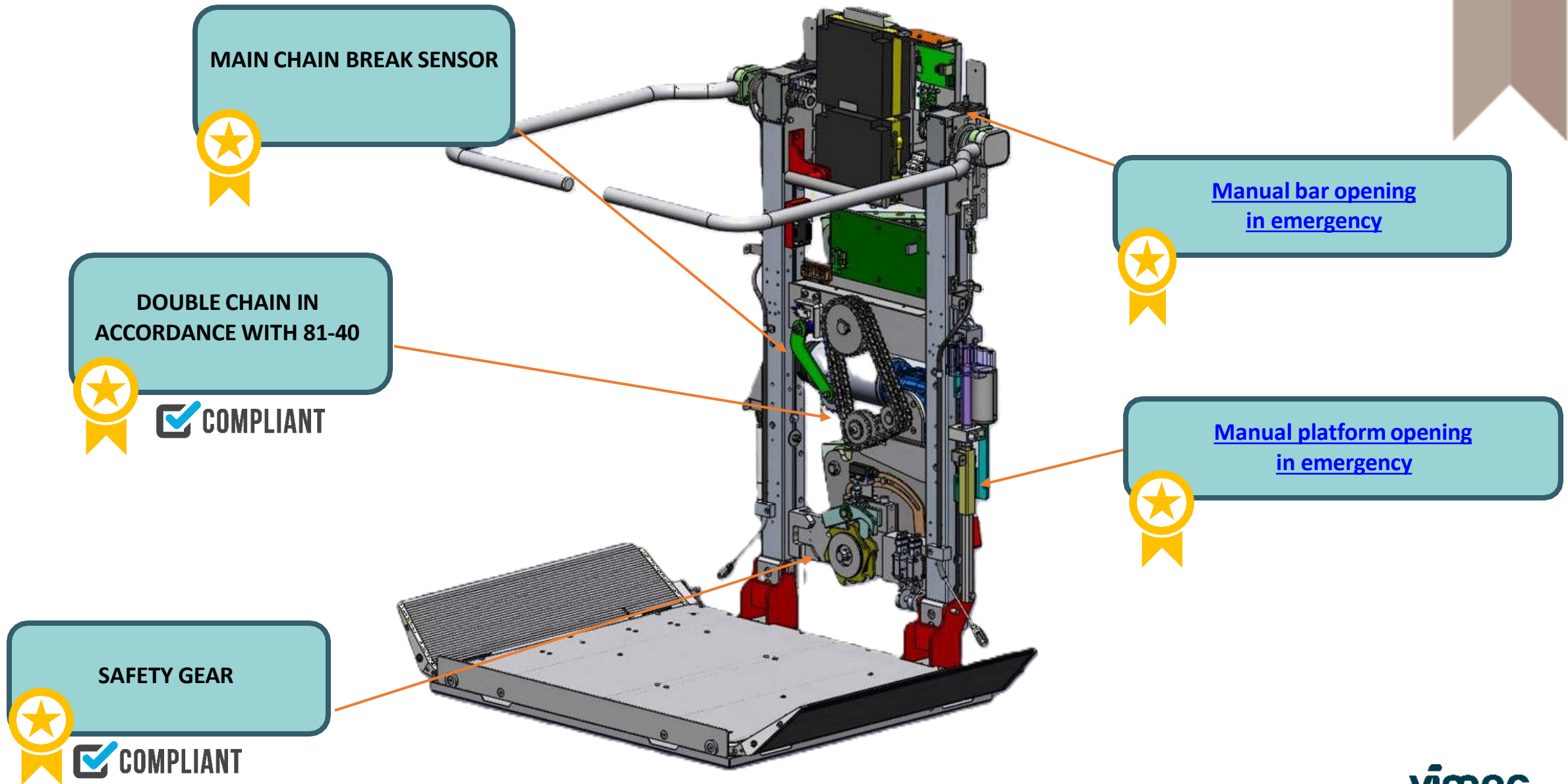

TRACTION

The traction system of the V6 is of the **rack and pinion type** on perforated guides.

V6 provides a standard:

- Double pinion
- Double towing chain equipped with a main chain break sensor (highlighted in **red**)

The mechanical safety gear and speed limiter (highlighted in **blue**) intervene in case of breakage of the traction organs or at a predetermined speed of descent higher than the nominal one.

The intervention of the device causes the machine to stop.

V6 is powered by 2 x 24 Vdc batteries that can be recharged at charging stations.

The power and consumption data from the mains are:

Voltage: 100-300 Vac

Maximum power consumption: 180W

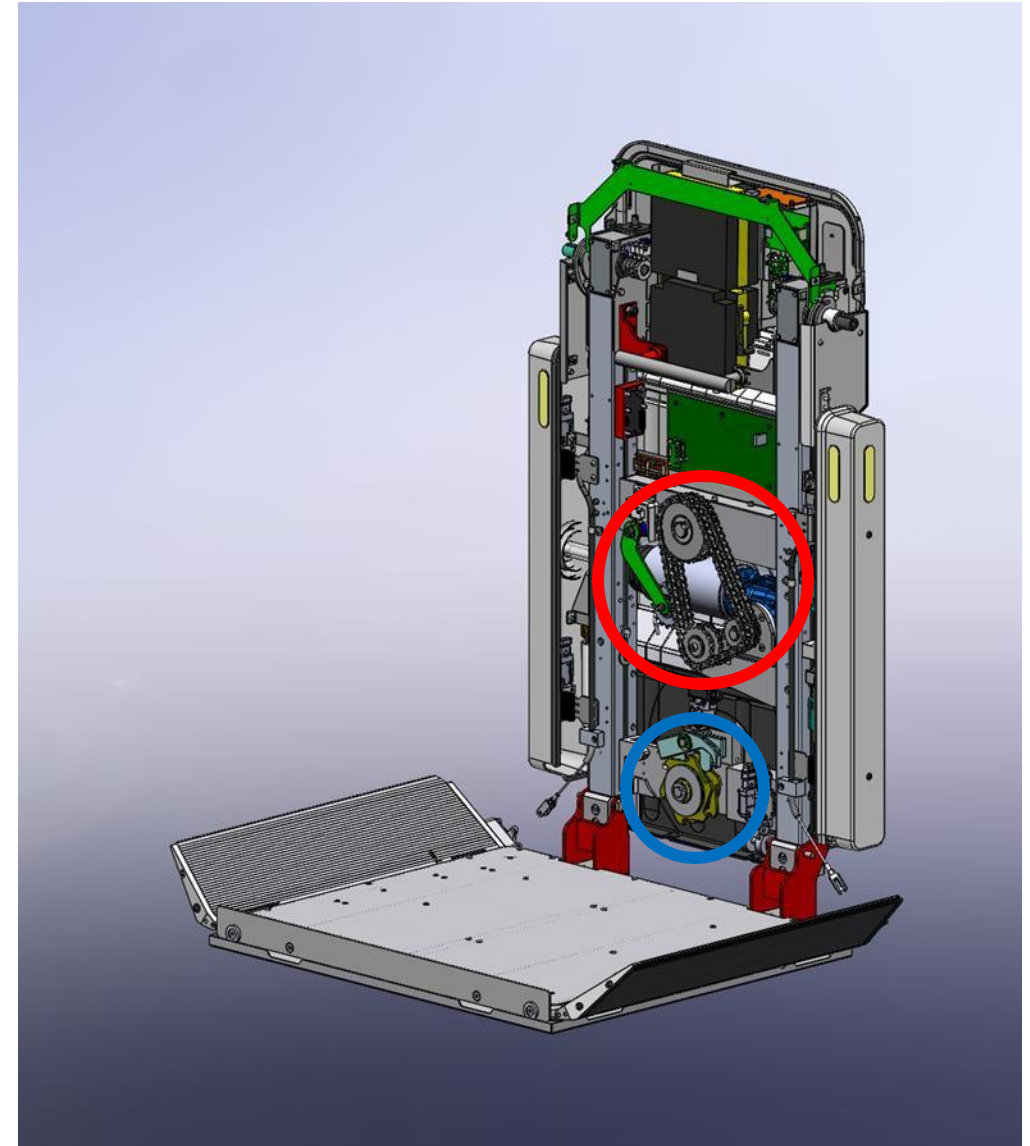



The standard rails of V6 are made of S355 steel and treated with sandblasting, epoxy painting and additional cataphoresis in case of outdoor installations.

The standard color of the guide is **RAL 7024 Graphite grey**.

N.B. It is possible to request an alternative colouring of the guide by warning the customer about the delicacy of this (in these cases the customer is required to fill out a dedicated form).

V6 comes standard with 2 charging stations located at the beginning and end of the guide, connected and with a single battery charger.

The "C" shaped guide rails' closing profile can be ordered separately, it is not part of the standard equipment.

NUOVO DESIGN

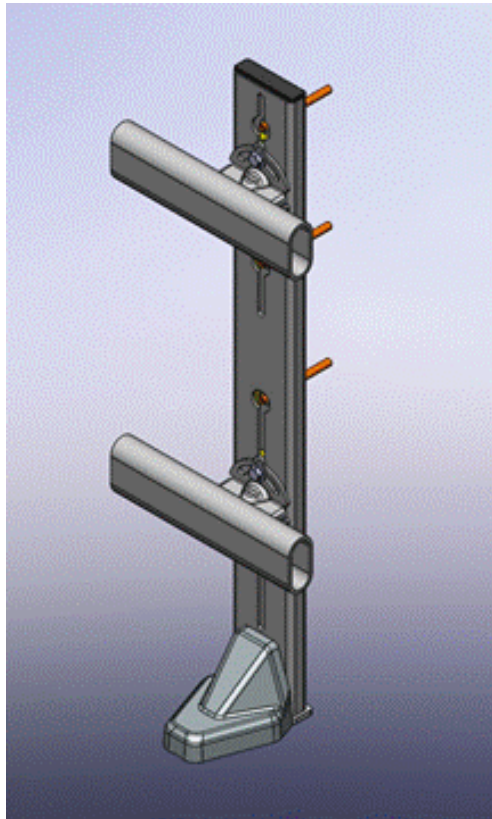

STANDARD FIXINGS
Made of steel RAL 7024

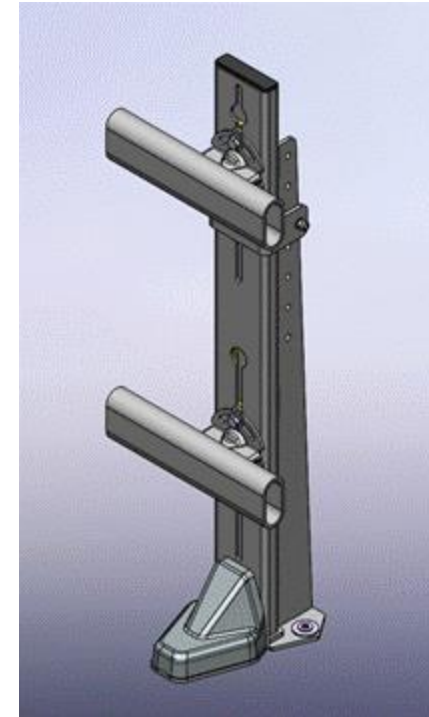

SELF-SUPPORTING FIXINGS
Made of steel RAL 7024

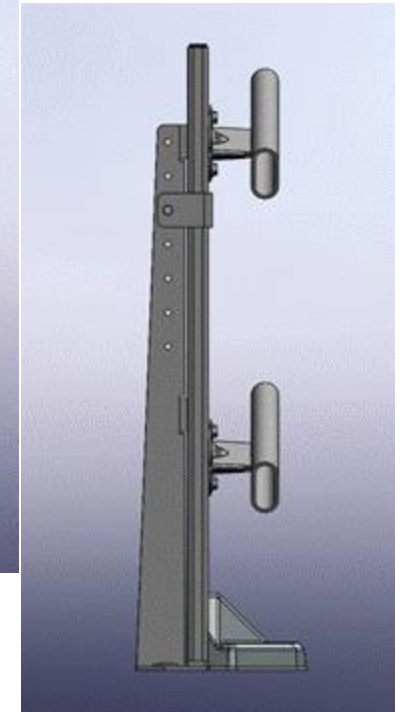

The jointing plates between fixing and guide are in galvanized steel.



As partly already discussed in the previous slides, V6 integrates numerous devices and measures that place it in first place among competitors in terms of safety.

Below, we list all the main security elements present on V6:

- **Protection bars**
- **Platform flaps and foot guard**
- **Double chain**
- **Manual unlocking of BARS and PLATFORM**
- **RESCUE MODE**
- **Electric and mechanical limit switches**
- **Shockproof, anti-skinning edges on the machine body and on the platform:** they stop the motion of the machine in contact with any obstacle. However, they allow the movement of the machine in the opposite direction to that in which the obstacle was encountered to free the way.
- **Safety edges under the platform**
- **Safety switches on side bumpers**
- **Inclinometer**
- **Safety gear and speed limiter:** intervenes in case of breakage of the traction organs or at a predetermined speed of descent higher than the nominal one. The intervention of the device causes the machine to stop.

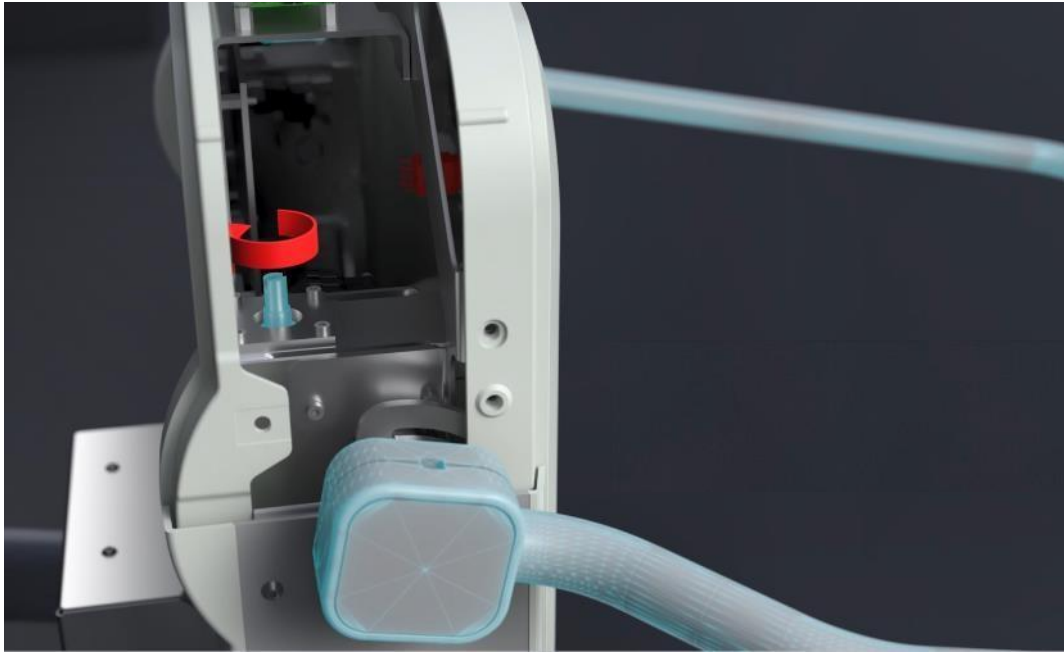

1. MANUAL UNLOCKING BARS

By removing the upper bonnet through a few simple operations, you can manually fold the bars down by acting on the small shaft indicated in the image on the left.

2. MANUAL PLATFORM UNLOCKING

By pressing the lever as shown in the image on the right, you can manually close the platform with the other hand – the operation can also be carried out by a single person.



SAFETY — RESCUE MODE



SAFETY

If the machine is blocked along the stair, it can be moved by a simple manual emergency manoeuvre or "**Rescue mode**". After unlocking the platform and arms, you act on the small shaft circled in red in the image through a tool supplied with the machine.

By turning the tool in the 2 directions it is possible to move the machine up or down.

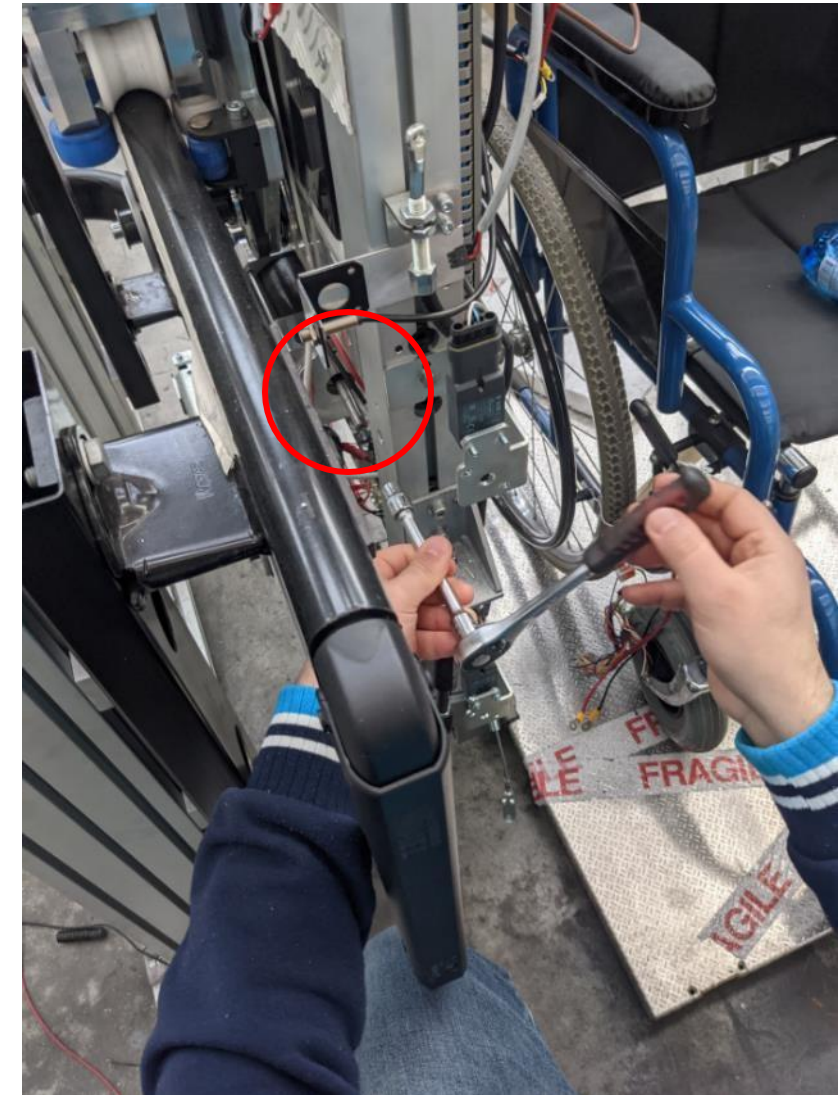

vimec

SALES MEMO – COLORS AND MATERIALS



GRAPHITE
GREY
RAL 7024

- Front cover
- Under-platform
- Footguard

SAME FOR BOTH VERSIONS:

RAL 7047

- Dashboard

RAL 9006

- Handrail
- Side flaps (and front where present)
- Side bumpers, bars and Upper cover
- Vimec logo

RAL 7024

- Rails and supports



PAPYRUS WHITE

RAL 9018

- Front cover
- Under-platform
- Footguard

vimec

SALES MEMO – COLORS AND MATERIALS

SAME FOR BOTH VERSIONS:



RAL 9006

Upper hood

RAL 7024

Rear covers



Natural almond aluminium
footboard

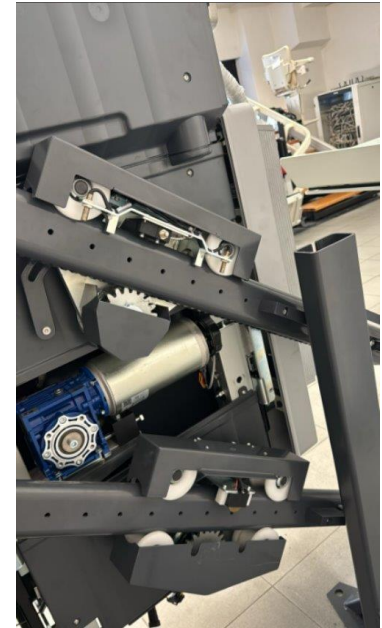
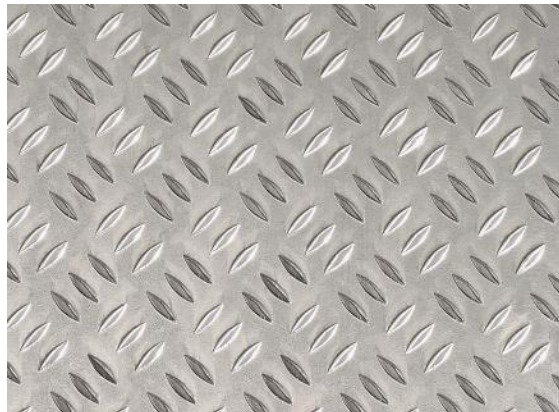

SALES MEMO – COLORS AND MATERIALS



RAL 7024

Fitting SMOOTH MATT

Rail SMOOTH

Flange ORANGE-PEEL GLOSSY

Rail end SMOOTH MATT

Foot ORANGE-PEEL GLOSSY

Foot cover SMOOTH MATT



SALES MEMO – SPECIAL RAL COLOURS

Special RAL colours are available
as option for:

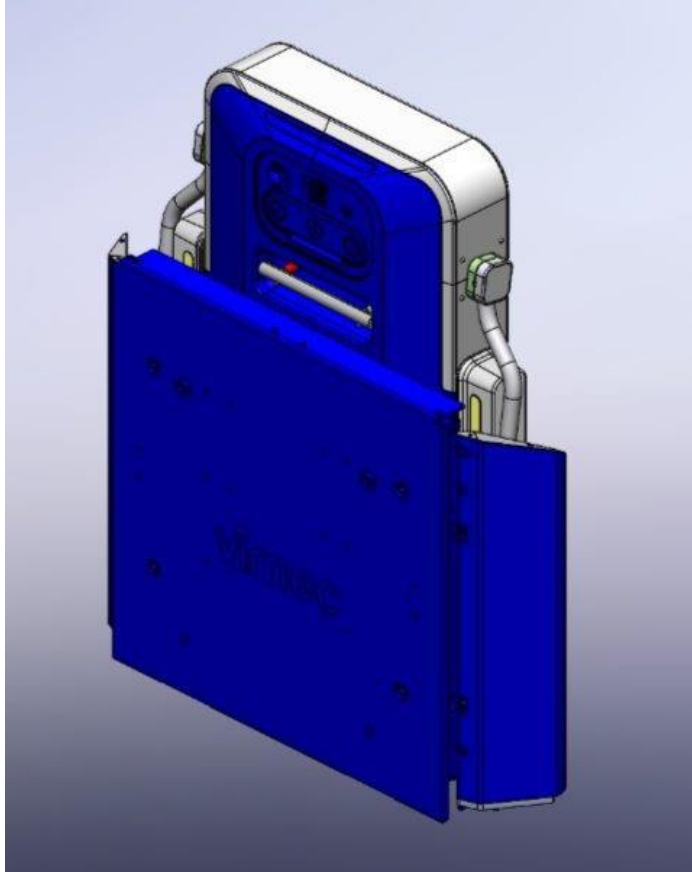

< Front side

(including front cover of
the machine body,
platform double bottom,
flaps and foot guard – side
bumpers, flaps' lateral
covers and upper hood not
included)

Rear side >

rear cover over the
machine body

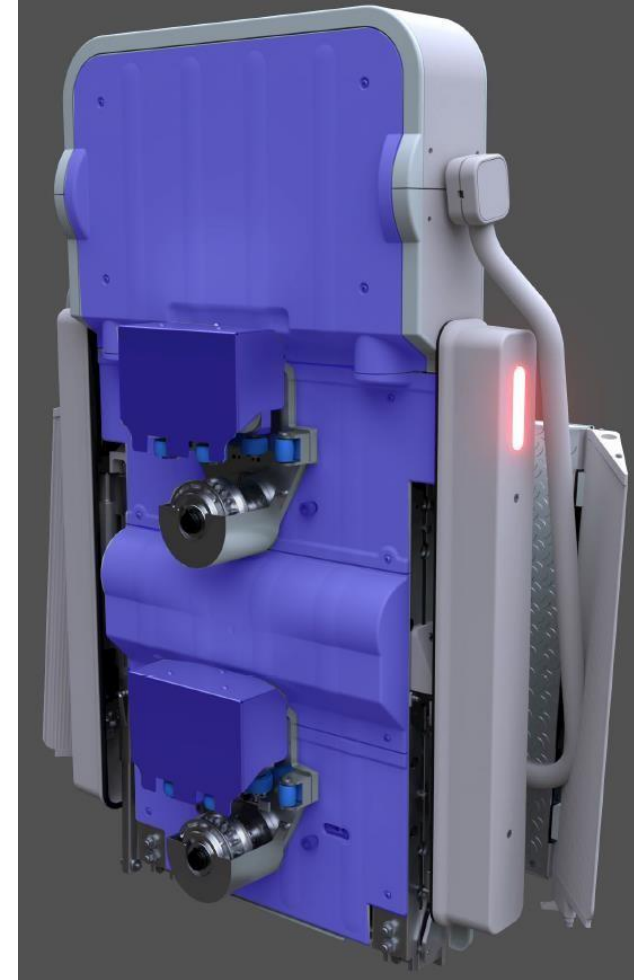

^

Rails and fittings (steel parts only, plastic covers and closures upon request)

SALES MEMO – COLORS AND MATERIALS



**CUSTOM WRAPPING ON
REQUEST**



ASSEMBLY

Machine Body in
ALUMINIUM



ONE MACHINE BODY FOR
RIGHT/LEFT VERSION



ONE MACHINE BODY FOR
INDOOR/OUTDOOR



ONE MACHINE BODY FOR ALL
PLATFORM SIZES



DIMENSIONS — OVERVIEW

NEW PLATFORM

V6 Australia

L	Platform width	1250
P	Platform depth	810
A*	Lateral Access	2850
B*	Landing rail footprint	1650
N*	Machine footprint on starting landing	1850
C*	Bars in working position	2110
LS	(With standard side access attachments)	1130
LS	(with standard side access attachments and front access)	NA

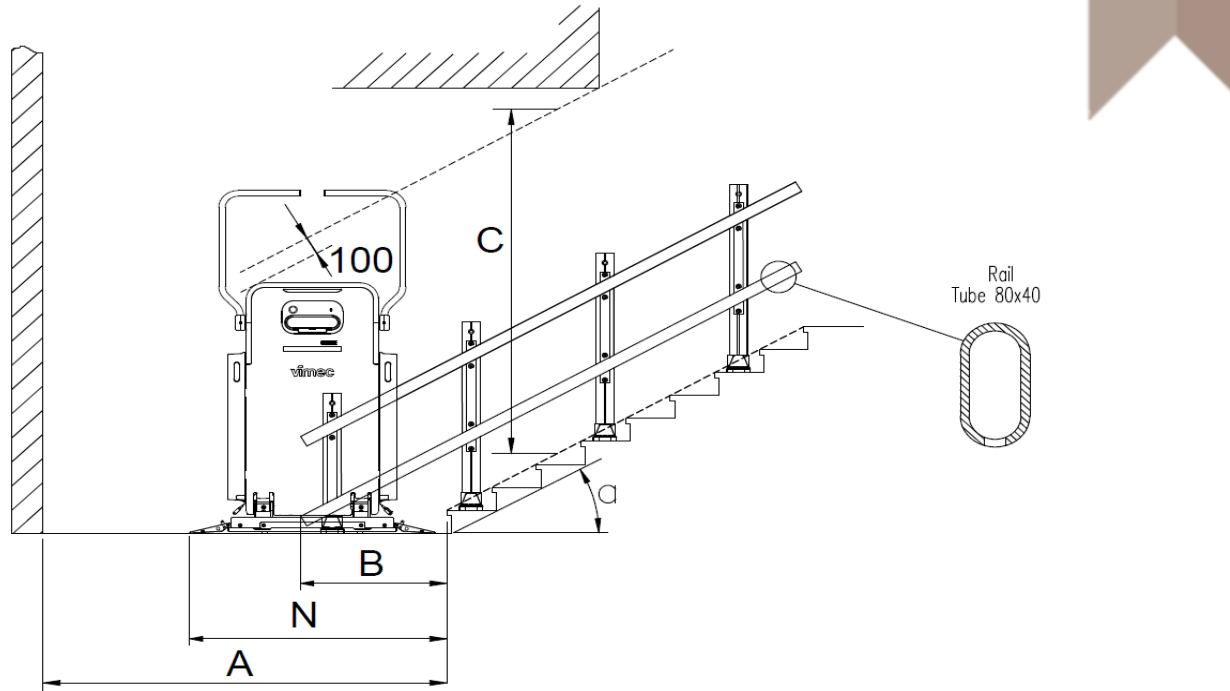

- with self-supporting supports+70mm
- with wall fixing -30mm

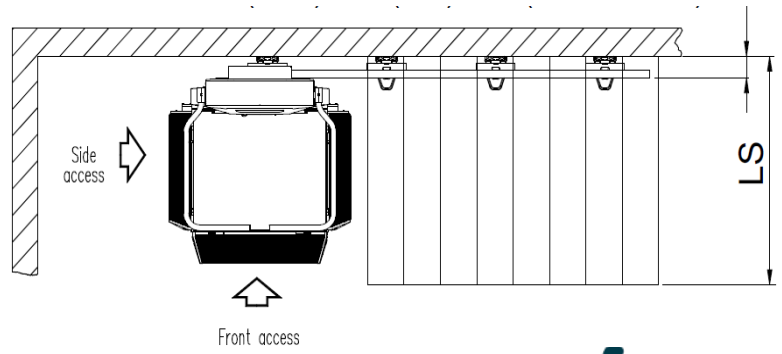

PLATFORM SIZE NOT AVAILABLE WITH 225KG CAPACITY



DIMENSIONS — OVERVIEW

NEW PLATFORM

V6 Australia		
L	Platform width	1250
P	Platform depth	810
H1*	Height with open bars	2020
T	Platform width with open flaps	1620
T1	Width with extended bars	1255
D	With standard foot guard	NA
D	With EN 81-40 foot guard (also with seat)	450
D	With front access	NA
R	Bar path Radius	895
I	With fixed foot guard	1130
W	with front access	NA

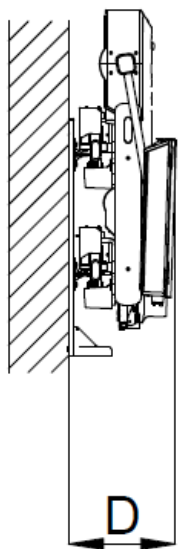
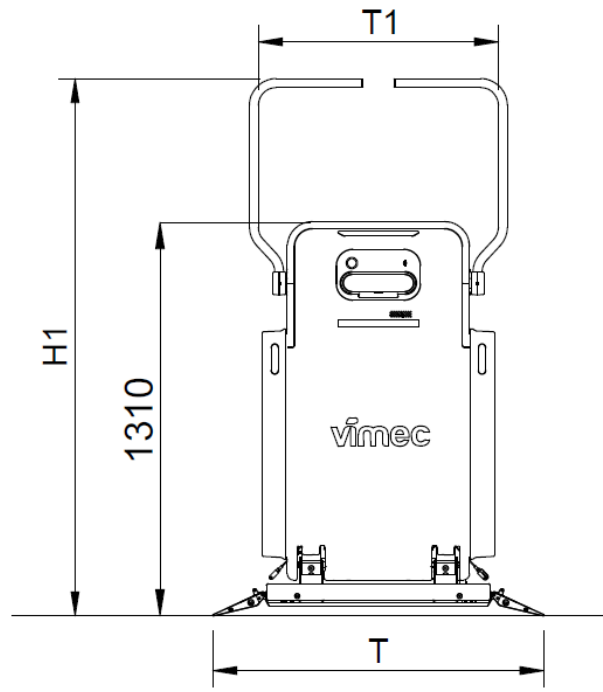

- with self-supporting supports +70mm
- with wall fixing -30mm

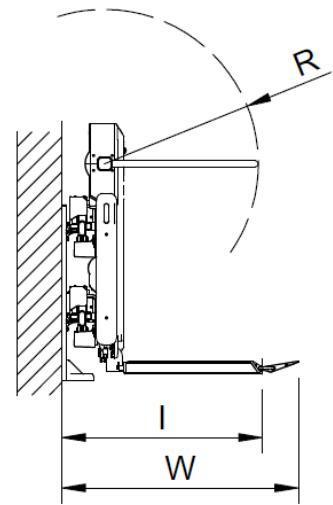

A silhouette of a person climbing a large rock formation against a sunset sky. The sun is low on the horizon, creating a bright glow and lens flare. The word "vimec" is overlaid in white lowercase letters on a dark circular background.

vimec